

# Semiautomated Fluorometric Determination of Rauwolfia Alkaloids

B. N. KABADI

**Abstract** □ A semiautomated nitrous acid fluorometric method for the determination of reserpine and rauwolfia alkaloids in unit dose is described. A simple, manual, alcoholic acid extraction method for the recovery of reserpine or reserpine-rescinnamine group alkaloids from a large number of tablets or powders is described. Following the chloroform extraction of the sample solution, the extract is washed with dilute hydrochloric acid and bicarbonate solutions and then reacted with nitrous acid to produce a yellowish-green fluorescence. The fluorogen is measured at an excitation wavelength maximum of 390 nm. and a fluorescent wavelength maximum of 510 nm. The automated system is designed to determine reserpine or rauwolfia alkaloids in the concentration range of 0.15–0.3 g. %. The rate of analysis of the samples is set at 20 an hour. Reserpine, yohimbine, and bendroflumethiazide do not interfere in the reserpine or rauwolfia alkaloids determination.

**Keyphrases** □ Reserpine—semiautomated fluorometric analysis □ Rauwolfia alkaloids—semiautomated fluorometric analysis □ Nitrous acid fluorometry—analysis, reserpine and rauwolfia alkaloids □ Fluorometry—analysis, reserpine and rauwolfia alkaloids

Simple extraction and determination of highly potent active ingredients in low concentration by a precise chemical procedure from products containing several components, some of natural origin, and unit dose analysis requirements for homogeneity are some of the new challenges faced by the pharmaceutical industry today. Often, the official assay method is not applicable to unit doses containing a low concentration of a drug such as *Rauwolfia serpentina* root tablets. By using a preliminary, manual, alcoholic acid extraction procedure, the determination of the reserpine-rescinnamine group alkaloids in pharmaceutical products containing rauwolfia root powder was automated based on a sensitive, nitrous acid fluorometric method.

The lengthy official extraction method for the recovery of rauwolfia alkaloids from root powders or tablets was not practical for automation. However, the alcoholic sulfuric acid extraction procedure of Kunze *et al.* (1) was suitable for the manual operation. This procedure, with some modifications, was adopted in this work.

The analytical procedures published for the quantitative determination of rauwolfia alkaloids are either colorimetric (2, 3) or fluorometric (4, 5). The colorimetric procedures are not sensitive and specific for the determination of low concentration level drugs. The specific *p*-toluenesulfonic acid fluorometric method for reserpine of Jakovljevic *et al.* (4), which is claimed to be sensitive, did not give reproducible results with rauwolfia alkaloids because of interference from the decomposition products. However, the author's previously reported (6) nitrous acid fluorescent method for reserpine, with modifications, was satisfactory for the automated determination. This procedure was extended to

the determination of reserpine in single tablets and in powders.

## EXPERIMENTAL<sup>1</sup>

**Reagents**—*Sulfuric Acid Reagent*—Forty milliliters spectral grade sulfuric acid was added to 1 l. of anhydrous methanol.

*Sodium Nitrite Reagent*—Two grams sodium nitrite was dissolved in 50 ml. distilled water and diluted to 1 l. with methanol.

*Hydrochloric Acid Reagent*—Twenty milliliters concentrated HCl was diluted to 1 l. with distilled water.

*Sodium Bicarbonate Reagent*—Twenty grams sodium bicarbonate was dissolved in 1 l. distilled water.

*0.5 N Sulfuric Acid Aqueous Reagent*—Fifteen milliliters concentrated sulfuric acid was added to 1020 ml. water.

*Chloroform Reagent*—Reagent grade chloroform was saturated with distilled water.

*Solvent*—Two hundred milliliters 0.5 N sulfuric acid in distilled water was added to 800 ml. anhydrous methanol (ACS grade).

**Standard Preparation**—Fifty milligrams reserpine USP reference standard, previously dried at 60° under reduced pressure for 3 hr., was transferred to a 500-ml. volumetric flask, dissolved in a few drops of chloroform, and diluted to volume with methanol (stock solution).

Ten milliliters of the reference standard stock solution was transferred to a second 100-ml. volumetric flask and diluted to volume with solvent (dilute stock solution). Working standards were prepared by diluting the reference standard dilute stock solution as follows. A series of seven aliquots in 1-ml. increments, ranging from 7 to 13 ml., was pipeted into seven 50-ml. volumetric flasks. Each flask was adjusted to volume with solvent.

**Sample Preparation**—Due to the volatile and corrosive nature of the solvent and to the slow dissolution of the active material, the Solid Prep Sampler module was not utilized. The following manual method was developed for the preparation of the sample.

The tablets or the weighed aliquot powders were placed separately in a series of 120-ml., amber, wide mouth, screw-cap bottles containing exactly 50–100 ml. solvent. The samples were pulverized carefully for 50 sec. by inserting the Polytron probe into the bottle. After pulverization, the liquid adhering to the probe was drained by rotating the blades at low speed. The sample bottles were capped and left standing for 20 min.

At the end of the 20-min. interval, a second homogenization of the sample was carried out with the Polytron. This procedure gave consistent results due to the disruption of the imbedded root cells and release of the active constituents into the solvent. Heating or centrifugation of the sample for clarification was not necessary.

**Assay Procedure**—The flow system and the manifold settings are shown in Fig. 1.

**Modifications in Manifold**—*Positive Chloroform-Displacement Attachment*—Initially, Acidflex manifold tubing was utilized to introduce chloroform into the system. However, the life of the Acidflex tubing carrying the reagent chloroform was short, and the precision of the analysis was poor. This was due to the resistance offered to the flow of chloroform by the beaded extractor coil. Therefore, the reagent Acidflex tubing was substituted in its place by a positive chloroform-displacement system.

The displacement system consisted of a 2-l. ground-glass stoppered bottle filled with chloroform. The glass inlet and outlet

<sup>1</sup> The following equipment was used: Technicon liquid sampler (Auto-analyzer); Technicon proportioning pump; Technicon line recorder; Technicon Turner fluorometer, model 111 (Technicon Corp., Tarrytown, N. Y.); and a Polytron blender, model PT-20 (Brinkmann Instrument Corp., Westbury, N. Y.).

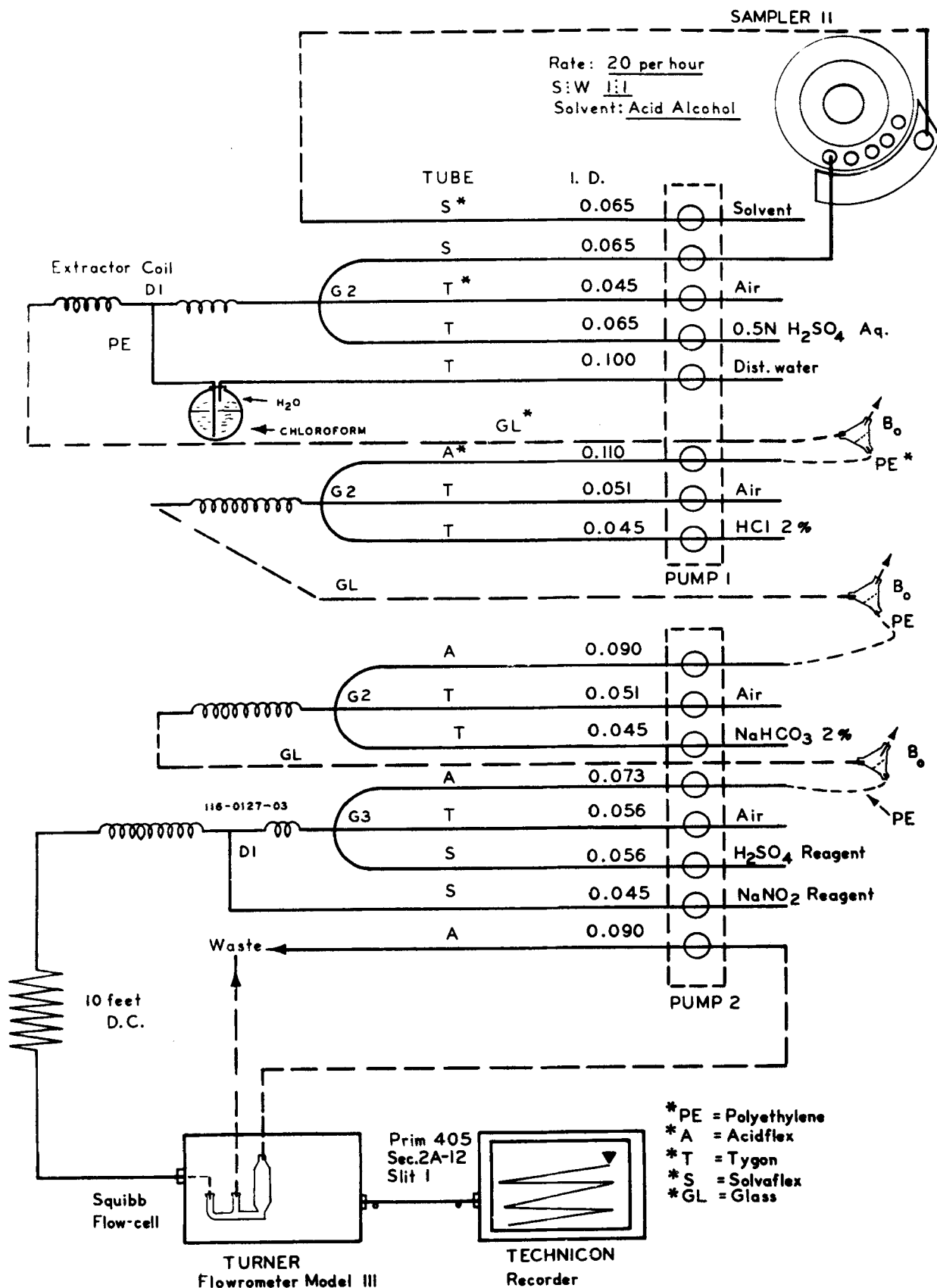

Figure 1—Flow diagram for the determination of rauwolfia alkaloids.

tubes were fused to the ground-glass stopper. The short inlet tube carrying the distilled water was connected to the pump through the heavy wall sleeving tubing. The long outlet tube, reaching to the bottom of the chloroform layer, was connected to the manifold

through the polyethylene tubing (i.d. 0.034). Before the displacement bottle was connected to the manifold system, it was completely filled with chloroform, leaving no air pockets. To prevent entrapped air from entering through the heavy wall water inlet tubing into

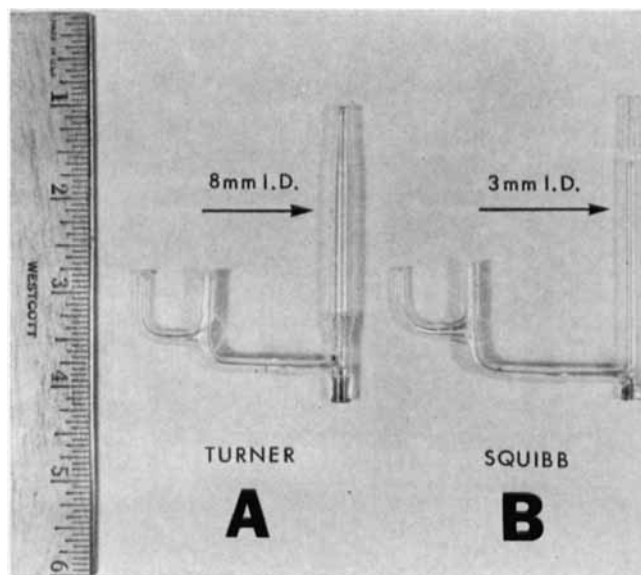

Figure 2—Modified flow cell. Key: A, Turner flow cell; and B, Squibb flow cell.

the bottle, this tubing was disconnected from the bottle at the beginning of pumping. After the tubing was completely filled with water, it was reconnected to the water inlet tube on the stopper of the displacement bottle. However, the polyethylene tubing carrying chloroform was initially connected directly both to the displacement bottle and to the manifold. This procedure ensured that no air bubbles were trapped in the reagent water, manifold water, or glass inlet tubes connecting the displacement bottle.

**Modifications of Automated Chemistry Door of Fluorometer**—The large flow cell of the fluorometer was originally held between two holders. It was attached to the sensitivity-boosting reflecting mirrors on the back and the large lens on the front. This flow cell was replaced by a homemade, small diameter, Pyrex glass flow cell (Fig. 2B). The mirrors, the lens, and the top holder were discarded. The new flow cell was held in position by its lower holder and was connected to the door through the Acidflex-inlet manifold, waste pick-up, and waste debubbler tubings.

## RESULTS AND DISCUSSION

Homogenization by a Polytron blender, using an alcoholic sulfuric acid solvent system, was found to be an efficient and quick manual extraction method for solids and powders. No heat was generated during the blending operation. Chloroform could not be used as a solvent due to its low penetrating power into the root cells of *rauwolfia* samples (7).

Table I—Comparison of Manual and Automated Methods

Product Description	Drug Weight	Constituent Analyzed	Manual Method	Automated Results <sup>a</sup> , mg./Sample	Manual Results, mg./Sample
Powdered <i>Rauwolfia serpentina</i> NF	Powder blend, 100 mg.	Reserpine-rescinnamine	NF	0.166	0.164
Tablet A <sup>c</sup>	<i>Rauwolfia</i> root powder, 100 mg.	Reserpine-rescinnamine	NF	0.165 0.164 <sup>b</sup> 0.171 <sup>b</sup> 0.170 <sup>b</sup>	0.164 0.158 0.173 0.164
Tablet B <sup>c,d</sup>	<i>Rauwolfia</i> root powder, 50 mg.	Reserpine-rescinnamine	NF	0.088 <sup>b</sup> 0.081 <sup>b</sup> 0.075 <sup>b</sup>	0.088 0.084 0.083
Tablet C <sup>c</sup>	Reserpine, 0.25 mg.	Reserpine	USP	0.240	0.233
Powder D <sup>c</sup>	Powder, 10 mg. Reserpine, 0.08 mg. <i>Rauwolfia</i> root	Reserpine	Squibb	0.088 0.087	0.084 0.085
Manufacturer X tablet	<i>Rauwolfia</i> root	Reserpine-rescinnamine	NF	0.170	0.167
Manufacturer Y tablet	<i>Rauwolfia</i> root powder, 100 mg.	Reserpine-rescinnamine	NF	0.173	0.169

<sup>a</sup> Different lots. <sup>b</sup> Average of 10 tablets (bulk of the tablets was the root powder; the tablet to tablet variation was small). <sup>c</sup> A = Squibb brand name Raudixin; B = Squibb brand name Rauzide; C = Squibb brand name Rau-sed; and D = Squibb brand name Orticalm. <sup>d</sup> Also contains 4 mg. bendroflumethiazide.

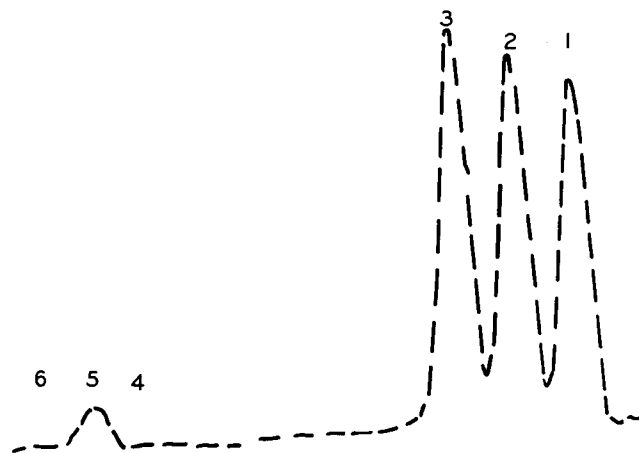

Figure 3—Recordings from fluorometric analysis. Key: 1, reserpine USP; 2, *R. serpentina* root powder; 3, rescinnamine; 4, blank, reserpine USP; 5, blank, *R. serpentina* root powder; and 6, blank, rescinnamine.

In the flow system (Fig. 1), the sample was aspirated and mixed with the aqueous sulfuric acid. This was necessary to prevent the formation of a homogeneous phase between the alcoholic sample and the chloroform on mixing. Chloroform was added to the diluted sample. The partitioning of the chloroform-soluble reserpine-rescinnamine alkaloids from the sample was accomplished in an extractor coil. As the liquids from the extractor emerged into the phase separator, the heavier chloroform phase was reaspirated continuously into the flow system. The chloroform extract was washed consecutively with dilute HCl and bicarbonate solutions in two separate double-mixing coils. This process removed the products of decomposition of reserpine-rescinnamine. The washed chloroform extract was then acidified and combined with nitrite reagent. The combined acid-nitrite/reserpine-rescinnamine solution was passed through a small delay coil to generate the optimum fluorescence. The recordings of this fluorescent solution were made at the excitation wavelength maximum of 390 nm. and an emission wavelength of 510 nm.

**Specificity and Stability Studies**—The semiautomated fluorometric method (6) for determining reserpine in tablets was not satisfactory for the determination of complex *rauwolfia* alkaloids. There was no interference by the excipients; however, there was considerable interference from the decomposition products of reserpine-rescinnamine. This interference was eliminated by the introduction of acid and base washings of the chloroform extracts of the sample.

The following experiments were carried out to demonstrate the specificity of the method for the analysis of reserpine-rescinnamine alkaloids.

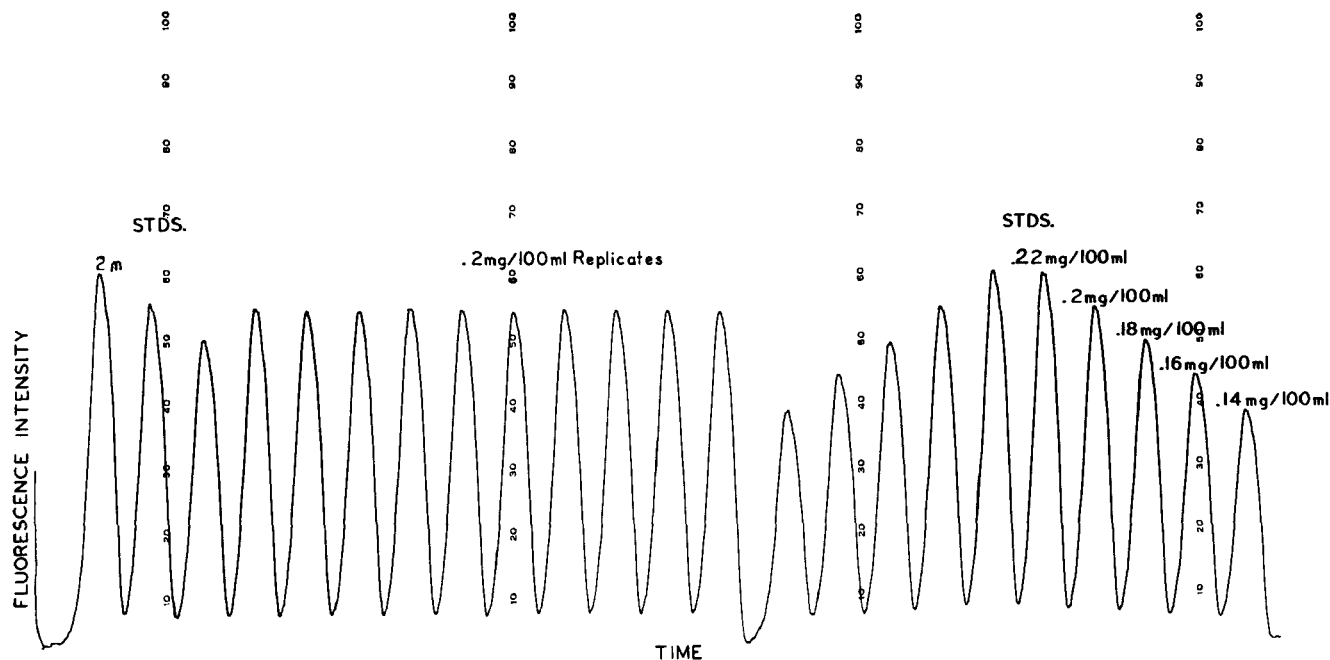

Figure 4—Reproducibility and effect of concentration on analysis of reserpine standard.

Figure 3 shows the results of the analysis of reserpine, rescinnamine, and rauwolfia root powder at 0.2-mg.% level for reserpine and rescinnamine and at 100-mg.% level for root powder. The recordings indicate that, at the same concentration level, reserpine has a lower fluorescence than rescinnamine (8).

Peaks 4, 5, and 6 of Fig. 3, corresponding to reserpine, rauwolfia root powder, and rescinnamine, were obtained with no sodium nitrite reagent added to the acidified chloroform extract. This is the normal blanking condition of the automated method. The appearance of no peaks from reserpine and rescinnamine (Peaks 4 and 6) and a definite small peak from the root powder under blanking conditions indicated interferences from nonalkaloidal fluorescent material. Therefore, blanking was necessary for the absolute determination of reserpine-rescinnamine group alkaloids. Generally, the blank values corresponded to 5-7% of the total value of the rauwolfia sample.

The related alkaloids, reserpidine and yohimbine (9), present in the *R. serpentina* species were analyzed using the automated system and were found not to interfere at the 5-mg.% level. It was reported (10) that alstonine, rauwolscine, sarpagine, and raunescine did not fluoresce when treated with nitrous acid. Bendroflumethiazide at the 8-mg.% level does not interfere in this automated analytical system.

**Sensitivity**—The sensitivity of the method increased due to the nonaqueous nature of the reaction system. Heat was not required to increase the sensitivity of the reaction, and this also prevented the evolution of nitrous acid gas from the reaction mixture. Adding excess  $\text{NaNO}_2$  and water to the nitrite reagent increased the fluorescence; however, excess water and nitrite precipitated when the reagent was added to the chloroform. Increasing the concentration of sulfuric acid in the reagent proportionately increased the fluorescence. However, the excess acid produced noise in the recordings and affected the flexibility of the manifold tubing.

**Precision and Accuracy**—The precision of the method was determined as the variability obtained upon repeated analysis of the reserpine standard. A relative standard deviation of a 0.0002% reserpine standard or samples on replicate analysis was less than 1%. Recordings of the various concentrations, even though not at steady state and with the baseline not returning completely to its original starting position, showed that there was no carryover (Fig. 4).

The accuracy of the procedure was studied by comparing the automated method with the manual method. Both analyses were made on the same pooled powdered samples. The automated analytical results were in general agreement with the manual results (Table I).

## SUMMARY

An automated nitrous acid fluorometric method for the determination of reserpine and rauwolfia alkaloids in unit doses was described.

A simple manual technique for the extraction of reserpine and rauwolfia alkaloids from the single tablets containing root powders was developed.

The effect of various interfering decomposition products of reserpine-rescinnamine on the analysis of rauwolfia alkaloids was discussed.

There was no interference from the excipients of tablets or of powder dosage forms or from reserpidine, yohimbine, and bendroflumethiazide.

## REFERENCES

- (1) F. M. Kunze, S. Barken, and D. Banes, *J. Ass. Offic. Agr. Chem.*, **51**, 157(1968).
- (2) "The National Formulary," 13th ed., Mack Publishing Co., Easton, Pa., 1970.
- (3) D. Banes, J. Wolff, H. O. Fallscheer, and J. Carol, *J. Amer. Pharm. Ass., Sci. Ed.*, **45**, 708(1956).
- (4) I. M. Jakovljevic, J. M. Fose, and N. R. Kuzel, *Anal. Chem.*, **34**, 410(1962).
- (5) W. H. McMullen, H. J. Pazdera, S. R. Missan, L. L. Ciaccio, and T. C. Grenfell, *J. Amer. Pharm. Ass., Sci. Ed.*, **44**, 446(1955).
- (6) B. N. Kabadi, A. T. Warren, and C. H. Newman, *J. Pharm. Sci.*, **58**, 1127(1969).
- (7) D. P. Page, *J. Ass. Offic. Anal. Chem.*, **53**, 815(1970).
- (8) S. R. Missan, L. L. Ciaccio, W. H. McMullen, H. J. Pazdera, and T. C. Grenfell, *J. Ass. Offic. Agr. Chem.*, **49**, 7(1960).
- (9) F. L. Weisenborn, M. Moore, and P. A. Diassi, *Chem. Ind.*, **1954**, 375.
- (10) C. R. Szalkowski and W. J. Mader, *J. Amer. Pharm. Ass., Sci. Ed.*, **45**, 613(1956).

## ACKNOWLEDGMENTS AND ADDRESSES

Received October 7, 1970, from *E. R. Squibb & Sons, New Brunswick, NJ 08903*

Accepted for publication August 3, 1971.

Presented at the Technicon International Congress on Automated Analysis, New York, N. Y., November 3, 1970.

Gratitude is expressed for the encouragement of A. T. Warren and C. H. Newman and for the technical assistance of N. K. Shah. The author also thanks Miss F. L. Moore, Squibb Institute for Medical Research, for supplying the compounds related to rauwolfia alkaloids.